

ALL-IN-ONE SOLAR HOME SYSTEM

Stefan Krauter, Fabian Ochs
UFRJ-COPPE-EE, PV-Labs, C. P. 68504, Rio de Janeiro 21945-970 RJ, Brazil
Tel: +55-21-2562-8032, Fax: +55-21-22906626, E-mail: krauter@coe.ufrj.br

ABSTRACT

Often SHS in remote areas do not reach their desired lifetime or do not work at all due to a deficit of trained people for correct installation and maintenance. The developed All-in-one SHS is facing these problems: All components such as support structure, foundation, PV modules, charge controller, DC-AC converter and wiring are pre-assembled by the manufacturer, and therefore installation in the field is reduced significantly. This reduces costs and the possibility of failures. While performance of crystalline Si-cells is increasing at reduced operation temperatures, the integrated cooling unit increases electrical yield by 9%. Reduction of cell temperatures performed by the integrated water tank – serving as the system's foundation as well - is neither expensive nor energy demanding, improving output of the system in an unproblematic way, and allowing optional use of the heated water.

INTRODUCTION

More than 20 million people in Brazil (ca. 42% of the rural population) do not have access to electricity. Grid line extension is a rather costly option, while distances are long and average consumption is low. According to [5] each km of a simple a 115 V line extension may cause initial costs in the vicinity of 50 000 €, depending on the region and the environment. In addition, costs for surveillance and maintenance are considerable while exposure of grid lines to hostile conditions is high (e.g. vandalism, thunderstorms, vegetation, flooding). A means to supply remote areas with electrical energy are Solar Home Systems (SHS). Apart from its ecological advantages in many cases this option is also the most economic way to electrify rural areas, especially when consumption is low and grid extension would be long. But even this most economic way has often a price that is too high for the wide spread of SHS. Also installation and service problems occur: according to a recent report [1] about 60% of the SHS installed in Brazil by the PRODEEM program are no longer working or even never worked at all. Reasons are a shortage of trained and educated staff that results in inadequate installations and

not properly maintained systems. Another reason for the high system failure rate was on the load side: The SHS installed have been equipped with a DC outputs only, which has the advantage that the user is not able to connect common (typically ineffective) electrodomestic equipment such as filament light bulbs, but on the other hand is rather difficult to find replacements in stores. Furthermore DC equipment (fuses, switches, fluorescent lamps etc.) is more expensive than for AC.

The All-in-one SHS developed is facing these problems: Reduction of system costs, increase of efficiency, minimized installation, high reliability and an AC output.

THE ALL-IN-ONE SHS

Composition of the system

Figure 1 shows the basic layout of the system: The PV generator consists of two parallel-connected frameless 30 W_P modules. In the foundation structure, a maintenance-free lead acid battery (12 V, 105 Ah) and a 200 W sine inverter (115 V 60 Hz) with an integrated charge controller (6 A) are located. A water tank cools all components. The output leads to a regular AC plug.

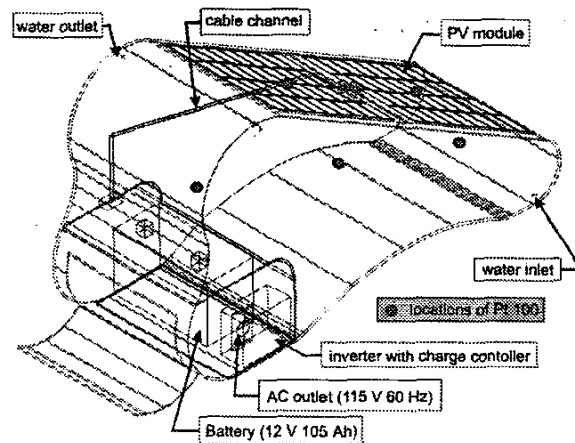

Fig. 1. Structure and components of the all-in-one SHS.

Additionally five Pt-100 temperature sensors have been integrated in the prototype. By computer based measurements - using a 16-channel-USB-DAC card and LabVIEW® software - the temperature profile has been studied in order improve the design towards most effective cooling. Also ambient temperature, irradiation and the electrical parameters (V, I, P) are sensed (see Fig. 2 and Fig. 4).



Fig. 2. The all-in-one SHS prototype during tests at Copacabana, Rio de Janeiro, Brazil.

All components are placed in a waterproof epoxy glass-fiber tank-container. The prototype is 1.37 m long, 0.76 m high and 0.5 m deep and has a volume of 0.3 m³ (see Fig. 2). A module elevation angle of 30° was chosen to achieve a good yield even in winter in most parts of Brazil. The container-tank has a volume of almost 300 liters, resulting in a weight of 300 kg, when filled up.

Temperature Dependence

The electrical power generation of a solar cell depends on its operation temperature. While the short circuit current (I_{sc}) increases slightly with increasing temperature, the open circuit voltage (V_{oc}) decreases significantly (about -2.3 mV for each K) with increasing temperature, leading to an electrical yield reduction of -0.4 %/K to -0.5 %/K for mono- and multi-crystalline Silicon solar cells which are used in most SHS applications.

Figure 3 shows the I - V -characteristics for a typical multi-crystalline Silicon solar cell at different temperatures together with the operation points for maximum power generation

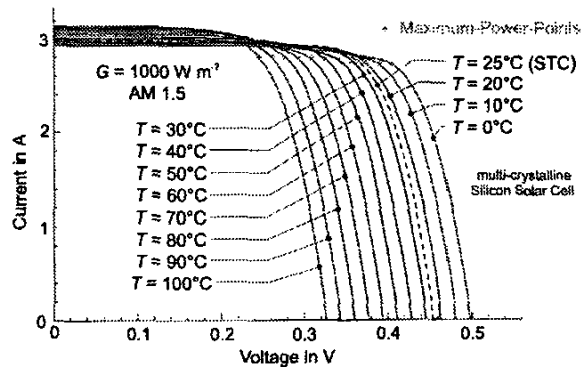

Fig. 3. I - V characteristics at different temperatures of a typical multi-crystalline Silicon solar cell.

Temperature Reduction

While efficiency and electrical yield is decreasing with increasing operation temperature, the idea to keep the system at low temperatures is quite evident. The energy consumption of an active cooling system would not be compensated by the gain in increased energy generation, at least for small systems. Keeping the operation temperatures at a low level by mounting the module on a water filled tank allows an effective reduction of operating cell temperature without spending any energy for refrigeration: The water virtually soaks up the heat flow generated by the module - due to the high thermal capacity of water incorporated ($C_{p,water} = 1254 \text{ kJ K}^{-1}$) the temperature is increasing just gradually (see also results in Fig. 5 and Fig. 6).

The principle was proven and validated at different prototypes in Europe and in Africa built in the last years [2,3,4]. The application to a complete system with all components integrated has been carried out for the first time.

Measurement System

Figure 4 shows the configuration of the measurement equipment. The sensor signals (temperatures of modules, water and ambient, global irradiance, module current and voltage, loads) get amplified, then digitalized by a 16 bit analog to digital converter (ADC) and finally mediated over a period of 10 minutes before being stored. The A-D sample rate is quite low (1 measurement every second). Visualization and submitting the data on the Internet is done via the LabVIEW® interface by National Instruments.

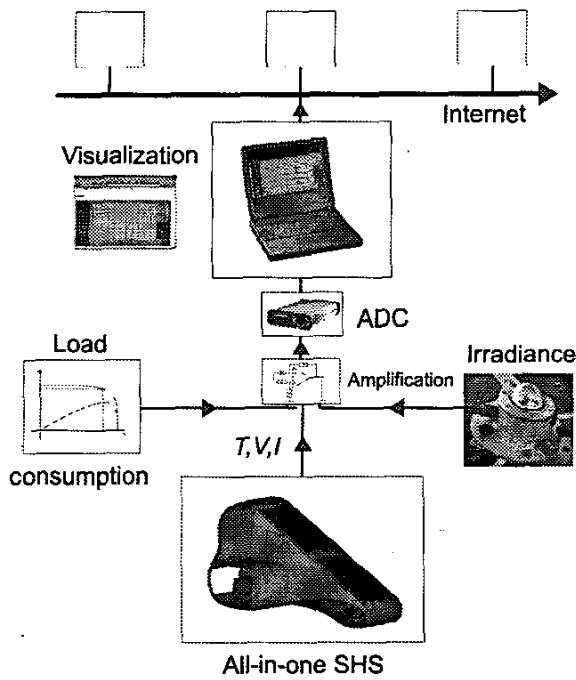

Fig. 4. Configuration of the measurement system for the All-in-one SHS.

RESULTS

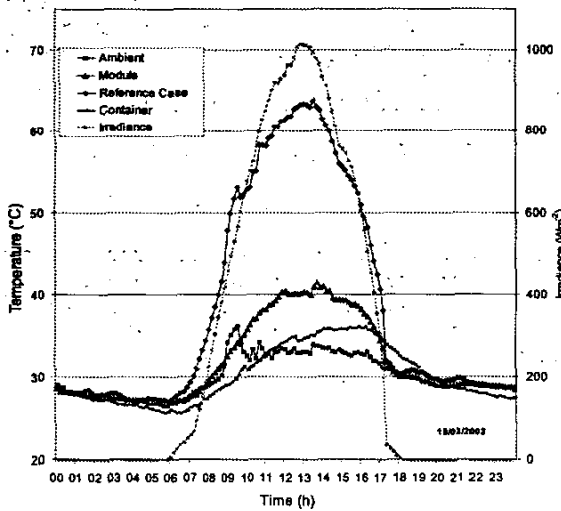

Fig. 5. Temperature measurements of All-in-one-system during a clear day: lower module temperature ("Module") and water temperature in upper part of the container ("Container"), in comparison to a standard module ("Reference Case") and ambient temperature ("Ambient").

The all-in-one device acts as an efficient cooler for the PV modules. The aluminum back of the frameless PV modules allows a good heat transfer to the container. The water tank with its high thermal capacity is limiting cell temperature close to ambient temperature (see Fig. 5).

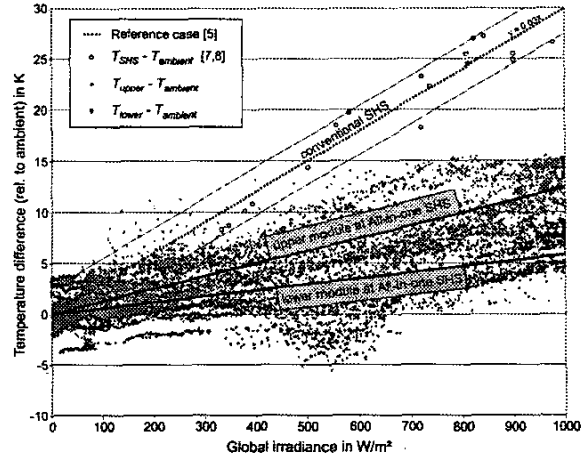

Fig. 6. Measured temperature differences between module and ambient in comparison to the reference case (standard SHS) plotted as a function of irradiance.

The increase of cell temperature relative to ambient temperature was measured for several days in March 2002 and is shown in Figure 6 for different levels of irradiance in comparison to the equivalent values for a conventional SHS [5,7,8]. Despite of a relative wide spread of values, mainly due to wind speed variations, the following linear approximations can be extracted:

$$T_{SHS} - T_{ambient} = 0.03 \cdot G \text{ (W/m}^2\text{)}^{-1} \text{ K} \quad (1)$$

$$T_{upper} - T_{ambient} = 0.012 \cdot G \text{ (W/m}^2\text{)}^{-1} \text{ K} \quad (2)$$

$$T_{lower} - T_{ambient} = 0.0058 \cdot G \text{ (W/m}^2\text{)}^{-1} \text{ K} \quad (3)$$

G stands for global irradiance, T_{SHS} for module operation temperature of a conventional SHS ("Reference Case") as measured [7,8] or given in literature [5,6]. T_{upper} stands for the temperature of the upper module and T_{lower} for the lower module integrated in the All-in-one system. All temperatures are given in Kelvin (K) or degree Celsius (°C).

In former experiments reduction of cell temperatures during operation times is able to increase electrical yield by up to 12% [3, 4]. Due the stratification observed (the upper part is considerable warmer than the lower one), the All-in-one system showed just a gain of 9%. Forcing circulation in the tank would certainly result in higher electrical yields. On the other hand – the stratification serves very well for an optional solar thermal use of the system: The hot water generated is sufficient for the hot

water consumption of a small household in Brazil. The upper module could be replaced by a thermal absorber and would boost hot water generation.

MANUFACTURING

For the tests a sole prototype has been manufactured. In mass production the manufacturing of (e.g. by PP or PE) will be fast and inexpensive. In large scale production costs should be less than 50 €. Material problems considering UV stability and drying out of the plastic seem to be solved: Manufacturers of similar tanks presently used for swimming ports, dare to give a guarantee of 10 years.

Prototype

The form of the prototype has been shaped out of a block of expanded Polystyrene (EPS). Subsequently the container-tank consisting of six parts was laminated using glass fiber and epoxy resin. To allow modifications the modules are mounted in a detachable way. A waterproof cable channel through the tank has been implemented. By the full integration of the modules into the tank, better thermal performance can be expected. Construction time for the prototype was less than a week. Material costs for the prototype have been 420 € and are listed in Table 1.

Table 1. Costs of materials for the structure of the prototype

Materials	Number, value	Unit	Cost (€)	Total cost (€)
Styrofoam	1	m ³	45	45
Glass fiber	30	m	5	150
Epoxy resin	5	kg	30	150
Glass bubbles	1	litres	25	25
Other	1		50	50
All				420

Balance of System Costs (BOS)

While foundation, support structure and mounting equipment are not needed anymore, a significant cost reduction of installed system costs can be observed. After placing the system at an appropriate site, it has just to be filled with water and is immediately ready to supply power to any AC device from its standard plug. The weight of the tank-container, without inverter and battery, is about seven kg, making transportation easy. Filled with water the container has a weight of more than 300 kg, turning the system stable enough to withstand every storm without further fixings.

CONCLUSION

The All-in-one SHS developed suits the requirements for electrification of rural areas. It is – once placed at an appropriate site – immediately ready to supply small AC loads (lightning, air-fan, radio etc.). Additionally it is also able to supply the hot water need for showering for a small household. Several systems can be combined to fulfill higher power needs without a redesign of the system. Without having higher costs than standard SHS, but featuring favorable BOS and generating more energy, it is an efficient means to successfully electrify remote areas.

REFERENCES

- [1] J. Kister, "O uso de Energia Solar no Brasil -Prodeem e posicionamento na situação atual", Thesis, UFRJ, 2000.
- [2] S. Krauter, "Solar Electricity up to 30% Less Expensive by Optical and Thermal Enhanced PV-Modules". *Proceedings of the ISES Solar World Congress 1995*, 1995.
- [3] S. Krauter, "Thermal and Optical Enhanced PV-Modules", *Proceedings of the 13th European Photovoltaic Solar Energy Conference*, 1995, pp. 2306-2309.
- [4] S. Krauter, R. Hanitsch, and L. Moreira, "New Optical and Thermal Enhanced PV Modules Performing 12% Better under True Module Rating Conditions", *Proceedings of the 25th IEEE-PV-Specialists Conference*, 1996, pp. 1323-1326.
- [5] R. Messenger and J. Ventre. *Photovoltaic Systems Engineering*, CRC Press, New York, 2000.
- [6] S. Krauter, R. Hanitsch, "Actual Optical and Thermal Performance of PV Modules", *Solar Energy Materials and Solar Cells* **41/42**, 1996, pp. 557-574.
- [7] S. Krauter, *Energetische Bilanzierung von Photovoltaik-Kraftwerken unter Berücksichtigung der Reduktion des anthropogenen CO₂-Ausstoßes*, VDI-Press, Düsseldorf, 1998
- [8] S. Krauter and U. Schmid, "Optical and Thermal Improvements of PV Performance by a Flowing Film of Water at the Frontside of PV Generators", *Proceedings of the 9th Sede Boquer Symposium on Solar Electricity Production*, 1999, p. 123-126.